

NOTA BENE:  
DISEGNO SCATOLA NON IN SCALA

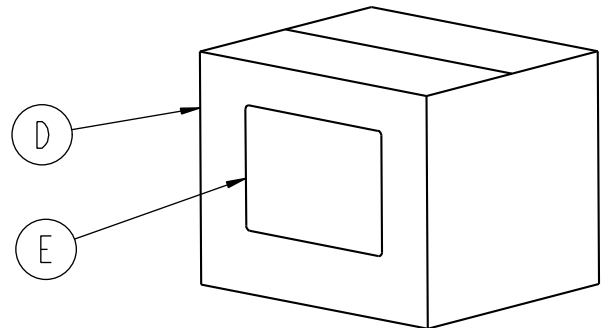

/	1/204	PZ.	88888840	PALLET IN LEGNO 800x120	LEGNO
/	1/825	PZ.	34600007	NASTRO IN PLP 50x660 AVANA	PPL
E	I	PZ.	521141810	ETICHETTA	TRANSFER PERMANENTE
D	I	PZ.	341302060	SCATOLA 20extx17.1x15.5	CARTONE A ONDA
C	I	PZ.	511812110	RACC.Ø60/100MF AL/AL +RC VERN.	/
B	I	PZ.	422001950	O-RING d.100 DOP. LABBRO EPDM OMOL.	EPDM EN 14241-1:2005 E - Classe T140 W2 K2 I
A	I	PZ.	42200150	O-RING DOPP. LABBRO d.60 SILIC.	SILICONE ROSSO 60
POS.	Q.TA'	UNITA' MISURA	COD. ARTICOLO	DESCRIZIONE	MATERIALE
APPROV.					
CONTROLL.					
DISEGN.	18/12/07				
EMISSIONE (REV.0.0)	DATA	FIRMA	REV.	DESCRIZIONE MODIFICA	DATA RED. CONTR. APPR.

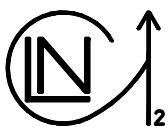

S.r.l. a socio unico

SCALA:

1:2

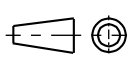

QUOTE SENZA IND. DI TOLLERANZA:  
GRADO DI PRECISIONE  
MEDIO UNI EN 22768 - m

MATERIALE:

/

DESCRIZIONE:

RACC.Ø60/100x163 MF AL/AL + RC

COD. ARTICOLO:

/

TRATT. TERMICO E/O SUPERF.

/

COD. DISEGNO:

/